

# Technical Disclosure Commons

---

Defensive Publications Series

---

November 2022

## A METHOD AND A CONNECTING DEVICE FOR ASSOCIATING USERS AND PHILANTHROPIC ENTITIES

MALAY GHOSH  
VISA

PAPAK MONDAL  
VISA

HUI MIN CHUA  
VISA

KELVIN WONG  
VISA

TAN SU YEE  
VISA

*See next page for additional authors*

Follow this and additional works at: [https://www.tdcommons.org/dpubs\\_series](https://www.tdcommons.org/dpubs_series)

---

### Recommended Citation

GHOSH, MALAY; MONDAL, PAPAK; CHUA, HUI MIN; WONG, KELVIN; YEE, TAN SU; and ROWTER, IMAAN, "A METHOD AND A CONNECTING DEVICE FOR ASSOCIATING USERS AND PHILANTHROPIC ENTITIES", Technical Disclosure Commons, (November 25, 2022)  
[https://www.tdcommons.org/dpubs\\_series/5533](https://www.tdcommons.org/dpubs_series/5533)



This work is licensed under a [Creative Commons Attribution 4.0 License](https://creativecommons.org/licenses/by/4.0/).

This Article is brought to you for free and open access by Technical Disclosure Commons. It has been accepted for inclusion in Defensive Publications Series by an authorized administrator of Technical Disclosure Commons.

---

**Inventor(s)**

MALAY GHOSH, PAPAK MONDAL, HUI MIN CHUA, KELVIN WONG, TAN SU YEE, and IMAAN ROWTER

**“A METHOD AND A CONNECTING DEVICE FOR  
ASSOCIATING USERS AND PHILANTHROPIC ENTITIES”**

**VISA**

**MALAY GHOSH  
PAPAK MONDAL  
HUI MIN CHUA  
KELVIN WONG  
TAN SU YEE  
IMAAN ROWTER**

## **TECHNICAL FIELD**

**[0001]** The present disclosure relates to the field of information management and collaboration. Particularly, the present disclosure relates to a method and a connecting device for associating users and philanthropic entities to help in community movement.

## **BACKGROUND**

**[0002]** Philanthropy has been essential for the advancement of society and betterment of human condition for many years. Many of the finest educational, health care, and religious institutions and activities have been a direct result of philanthropic donations and activities. The resulting institutions, services, and products not only often fulfill substantial voids that have not been, and often cannot be, met by government, but also expand the range of options and competitive alternatives to institutions, services, and products provided by the government and non-philanthropic private activities and entities. The net result is not only a more efficient allocation of resources in the market and society, but also substantial increases the quality of societal morals, education, human interaction, spiritual accomplishment, and life all across society.

**[0003]** In the existing society, there are many philanthropic entities which focus on specific social causes and serve the public at large. The donations provided by the philanthropic entities save lives during humanitarian disasters and improve nutrition of vulnerable communities. However, in the existing scenario, most of the common people are unaware of philanthropic entities. Thus, there is a need for a system which provides such awareness and involves more people in participating in community movements for the welfare of society.

## **BRIEF DESCRIPTION OF THE DRAWINGS**

**[0004]** Additional advantages and details of non-limiting embodiments are explained in greater detail below with reference to the exemplary embodiments that are illustrated in the accompanying schematic figures, in which:

**[0005]** **FIG.1** shows an exemplary embodiment for associating users and philanthropic entities to help in community movement, in accordance with some embodiments of the present disclosure;

[0006] FIG.2 shows a flow diagram that illustrates a method of onboarding users during registration process to associate the users and philanthropic entities, in accordance with some embodiments of the present disclosure;

[0007] FIG.3 shows a flow diagram that illustrates a method of associating users and a philanthropic entity to participate in charity program during non-Point-of-Sale (POS) transactions, in accordance with some embodiments of the present disclosure;

[0008] FIG.4 shows a flow diagram that illustrates a method of associating users and a philanthropic entity to participate in charity program during Point-of-Sale (POS) transactions, in accordance with some embodiments of the present disclosure; and

[0009] FIG.5 shows an exemplary scenario for associating users and charity organizations to help in community movement, in accordance with some embodiments of the present disclosure.

### **DESCRIPTION OF THE DISCLOSURE**

[0010] In the present document, the word "exemplary" is used herein to mean "serving as an example, instance, or illustration." Any embodiment or implementation of the present subject matter described herein as "exemplary" is not necessarily to be construed as preferred or advantageous over other embodiments.

[0011] While the disclosure is susceptible to various modifications and alternative forms, specific embodiment thereof has been shown by way of example in the drawings and will be described in detail below. It should be understood, however that it is not intended to limit the disclosure to the particular forms disclosed, but on the contrary, the disclosure is to cover all modifications, equivalents, and alternative falling within the spirit and the scope of the disclosure.

[0012] The terms "comprises", "comprising", or any other variations thereof, are intended to cover a non-exclusive inclusion, such that a setup, device or method that comprises a list of components or steps does not include only those components or steps but may include other components or steps not expressly listed or inherent to such setup or device or method. In other words, one or more elements in a device or system or apparatus proceeded by "comprises... a"

does not, without more constraints, preclude the existence of other elements or additional elements in the device or system or apparatus.

**[0013]** The terms "an embodiment", "embodiment", "embodiments", "the embodiment", "the embodiments", "one or more embodiments", "some embodiments", and "one embodiment" mean "one or more (but not all) embodiments of the invention(s)" unless expressly specified otherwise.

**[0014]** The terms "including", "comprising", "having" and variations thereof mean "including but not limited to", unless expressly specified otherwise.

**[0015]** For purposes of the description hereinafter, the terms "end," "upper," "lower," "right," "left," "vertical," "horizontal," "top," "bottom," "lateral," "longitudinal," and derivatives thereof shall relate to the invention as it is oriented in the drawing figures. However, it is to be understood that the invention may assume various alternative variations and step sequences, except where expressly specified to the contrary. It is also to be understood that the specific devices and processes illustrated in the attached drawings, and described in the following specification, are simply exemplary embodiments or aspects of the invention. Hence, specific dimensions and other physical characteristics related to the embodiments or aspects disclosed herein are not to be considered as limiting.

**[0016]** As used herein, the terms "communication" and "communicate" may refer to the reception, receipt, transmission, transfer, provision, and/or the like of information (e.g., data, signals, messages, instructions, commands, and/or the like). For one unit (e.g., a device, a system, a component of a device or system, combinations thereof, and/or the like) to be in communication with another unit means that the one unit is able to directly or indirectly receive information from and/or transmit information to the other unit. This may refer to a direct or indirect connection (e.g., a direct communication connection, an indirect communication connection, and/or the like) that is wired and/or wireless in nature. Additionally, two units may be in communication with each other even though the information transmitted may be modified, processed, relayed, and/or routed between the first and second unit. For example, a first unit may be in communication with a second unit even though the first unit passively receives information and does not actively transmit information to the second unit. As another example, a first unit may be in communication with a

second unit if at least one intermediary unit (e.g., a third unit located between the first unit and the second unit) processes information received from the first unit and communicates the processed information to the second unit. In some non-limiting embodiments, a message may refer to a network packet (e.g., a data packet and/or the like) that includes data. It will be appreciated that numerous other arrangements are possible.

**[0017]** As used herein, the term “merchant” may refer to an individual or entity that provides goods and/or services, or access to goods and/or services, to customers based on a transaction, such as a payment transaction. The term “merchant” or “merchant system” may also refer to one or more computer systems operated by or on behalf of a merchant, such as a server computer executing one or more software applications. A “point-of-sale (POS) system,” as used herein, may refer to one or more computers and/or peripheral devices used by a merchant to engage in payment transactions with customers, including one or more card readers, near-field communication (NFC) receivers, RFID receivers, and/or other contactless transceivers or receivers, contact-based receivers, payment terminals, computers, servers, input devices, and/or other like devices that can be used to initiate a payment transaction.

**[0018]** As used herein, the term “user” may include an individual. In some embodiments, a user may be associated with one or more personal accounts and/or mobile devices. The user may also be referred to as a cardholder, account holder, or user in some embodiments.

**[0019]** As used herein, the term “user device” may be a device that is operated by a user. Examples of user devices may include a mobile phone, a smart phone, a card, a personal digital assistant (PDA), a laptop computer, a desktop computer, a server computer, a thin-client device, a tablet PC, etc. Additionally, user devices may be any type of wearable technology device, such as a watch, earpiece, glasses, etc. The user device may include one or more processors capable of processing user input. The user device may also include one or more input sensors for receiving user input. As is known in the art, there are a variety of input sensors capable of detecting user input, such as accelerometers, cameras, microphones, etc. The user input obtained by the input sensors may be from a variety of data input types, including, but not limited to, audio data, visual data, or biometric data. The user device may comprise any electronic device that may be operated by a user, which may also provide remote communication capabilities to a network. Examples of

remote communication capabilities include using a mobile phone (wireless) network, wireless data network (e.g., 3G, 4G or similar networks), Wi-Fi, Wi-Max, or any other communication medium that may provide access to a network such as the Internet or a private network. A user device may also be a credit, debit, or prepaid card.

**[0020]** As used herein, the term “resource provider” can be any suitable entity that provides resources (e.g., goods, services, access to secure data, access to locations, or the like) during a transaction. For example, a resource providing entity can be a merchant, a venue operator, a building owner, a governmental entity, etc. A “merchant” may typically be an entity that engages in transactions and can sell goods or services or provide access to goods or services.

As used herein, the term “authorizing entity” may be an entity that authorizes a request, typically using an authorizing computer to do so.

**[0021]** It will be apparent that systems and/or methods described herein can be implemented in different forms of hardware, software, or a combination of hardware and software. The actual specialized control hardware or software code used to implement these systems and/or methods is not limiting of the implementations. Thus, the operation and behavior of the systems and/or methods are described herein without reference to specific software code, it being understood that software and hardware can be designed to implement the systems and/or methods based on the description herein.

**[0022]** Some non-limiting embodiments or aspects are described herein in connection with thresholds. As used herein, satisfying a threshold may refer to a value being greater than the threshold, more than the threshold, higher than the threshold, greater than or equal to the threshold, less than the threshold, fewer than the threshold, lower than the threshold, less than or equal to the threshold, equal to the threshold, etc.

**[0023]** **FIG.1** shows an exemplary embodiment for associating users and philanthropic entities to help in community movement, in accordance with some embodiments of the present disclosure.

**[0024]** In **FIG.1**, a schematic diagram of a system **100** includes a user device **101**, a connecting device **103**, and a philanthropic entity **105**. Initially, a user may perform a transaction using the user device **101**. The user device **101** may include, but not limited to, a mobile phone, a smart



phone, a card, a personal digital assistant (PDA), a laptop computer, a desktop computer, a server computer, a thin-client device, a tablet PC, and the like. Upon the initiation of transaction, an authorization entity associated with the connecting device **103** may determine whether the user device **101** is enrolled in a charity program associated with the philanthropic entity **105** (Not shown in FIG. 1). Further, the connecting device **103** may transmit a request to the philanthropic entity **105** requesting for event data associated with the charity program. The philanthropic entity **105** may include a non-profitable organization or a charity organization. Based on the request, the connecting device **103** may receive the event data associated with the charity program from the philanthropic entity **105**. The event data may include quiz/questions provided by the philanthropic entity **105** to collaborate for donation of charity. For example, the non-profitable organization may transmit a set a quiz questions, where for each correct answer, 10 grains of rice may be donated. Upon receiving the event data associated with the charity program, the connecting device **103** may transmit the received event data associated with the charity program to the user device **101**. Subsequent to the transmission of the event data, the connecting device **103** may receive a response provided by the user device **101** for the event data. Finally, the connecting device **103** may trigger the contribution as charity to the philanthropic entity **105** based on the received response.

**[0025]** FIG.2 shows a flow diagram that illustrates a method of onboarding users during registration process to associate the users and philanthropic entities, in accordance with some embodiments of the present disclosure.

**[0026]** As illustrated in FIG. 2, the method **200** comprises one or more blocks implemented for onboarding users during registration process. The method **200** may be described in the general context of computer executable instructions. Generally, computer executable instructions can include routines, programs, objects, components, data structures, procedures, modules, and functions, which perform specific functions or implement specific abstract data types.

**[0027]** The order in which the method **200** is described is not intended to be construed as a limitation, and any number of the described method blocks can be combined in any order to implement the method. Additionally, individual blocks may be deleted from the methods without departing from the spirit and scope of the subject matter described herein. Furthermore, the method can be implemented in any suitable hardware, software, firmware, or combination thereof.

**[0028]** The steps of the method shown may be carried out during user registration process before the user device **101** initiates a transaction. At block **201**, initially, the user may approach an issuer bank to sign up or issue a credit or debit card (For example Visa credit card or Visa debit card). At block **203**, the user may fill up an onboarding form provided by the issuer bank. The onboarding form may include an option for charity program for which the user may contribute. The user may either decide to contribute or to not contribute to the charity program by selecting an appropriate option in the onboarding form. At block **205**, the issuer bank may send the data provided in the onboarding form to an authentication entity through an Application Programming Interface (API). The authentication entity is an entity which verifies the identity of the users. The authentication entity may authenticate user details provided in the onboarding form. Upon successful authentication, at block **207**, the authorization entity may verify if the user has opted to enroll in the charity program. The authorization entity may be an entity which determines the access rights of the users. For example, the authorization entity may verify whether the user has opted to participate in the charity program. At block **209**, if it is detected that the user has opted to enroll in the charity program, then the user is enrolled for the charity program through an API. At block **211**, if the user has not opted for the enrollment, then the authorization entity enrolls the users only for the card and not for the charity program. Once the user is successfully registered, the user may initiate a transaction using the user device **101** with the merchant.

**[0029]** **FIG.3** shows a flow diagram that illustrates a method of associating the users and a philanthropic entity to participate in charity program during non-POS transactions, in accordance with some embodiments of the present disclosure.

**[0030]** As illustrated in FIG. 3, the method **300** comprises one or more blocks implemented for prompting the users to participate in the charity program of the philanthropic entity **105** during non-POS transactions. The steps of the method **300** shown may be carried out by the connecting device **103** to prompt the users to participate in the charity program. At block **301**, the user may initiate a transaction with a merchant for goods/services. The transaction performed by the user may be a non-POS transaction, such as, using a credit card, debit card or through online. At block **303**, upon the initiation of the transaction, the merchant may send the transaction data to the authentication entity. For example, the authentication entity may be VisaNet. Further, at block **305**, the authentication entity authenticates the user and confirms the transactions with the issuer

bank and an acquirer bank. Upon successful authentication, at block **307**, the authorization entity may check whether the user device **101** performing the transaction is enrolled in the charity program. If the user device **101** is determined to be enrolled in the charity program, then at block **309**, the authorization entity connects to the connecting device **103** through an API. Further, at block **311**, the connecting device **103** connects to the philanthropic entity **105** through an API. At block **313**, the connecting device **103** may send the event data associated with the charity program for providing the charity to the access points via an API. However, if the user device **101** is determined to be not enrolled in the charity program, then, at block **315**, the authorization entity may trigger the access points for further processing of the transaction. Finally, at block **317**, the access point may again check if the user is enrolled in the charity program. Further at block **319**, if the user is enrolled in charity program, the access point may send a communication (for example an SMS and/or email confirmation) regarding the transaction to the users along with the event data. Also at block **321**, the user may choose an option or provide a response to the received event data via a communication medium such as, an SMS or email. At block **323**, if the user is not enrolled in the charity program, then the access point may send a confirmation message regarding the transaction to the user device **101**.

**[0031]** FIG.4 shows a flow diagram that illustrates a method of associating the users and philanthropic entity to participate in charity program during POS transactions, in accordance with some embodiments of the present disclosure.

**[0032]** As illustrated in FIG. 4, the method **400** comprises one or more blocks implemented for prompting the users to participate in the charity program of the philanthropic entity **105** during POS transactions. The steps of the method 400 shown may be carried out by the connecting device **103** to prompt the users to participate in the charity program. At block **401**, the user may perform a transaction at a Point-of-Sale (POS) at a merchant store. Further, at block **403**, the merchant may send the transaction data to the authentication entity. At block **405**, the authentication entity may confirm the transaction performed by the user with the issuer bank and the acquirer bank. , At block **407**, the authorization entity may check if the user has enrolled in the charity program. If the user is determined to be enrolled in the charity program, at block **409**, the authorization entity triggers the connecting device **103** using an API to connect with the philanthropic entity **105**. Further, at block **411**, the connecting device **103** connects with the philanthropic entity **105** via an

entity API to retrieve the event data associated with the charity program for providing charity. At block **413**, the connecting device **103** may send the retrieved event data to the access point via an API. However, if the user is determined to be not enrolled in the charity program, then at block **415**, the authorization entity may call the access point API to confirm the transaction performed. Upon the successful transaction, at block **417** the access point may check whether the user is enrolled to the charity program. If the user is not enrolled in the charity program, then at block **419**, the access point may display the transactions data on the POS. However, if the user is enrolled to the charity program, then at block **421**, the access point may display the transaction data and the event data on the POS. Further, at block **423**, the user may choose whether or not to answer the questions associated with the event data provided on the POS. At block **425**, the user may provide an appropriate response by choosing the right option to the questions displayed on the POS. At block **427**, the user may press cancel if the user does not wish to answer the questions displayed on the POS.

**[0033]** FIG.5 shows an exemplary scenario for associating users and charity organizations to help in community movement, in accordance with some embodiments of the present disclosure.

**[0034]** As illustrated in FIG.5, the connecting device **103** may associate the users and the charity organizations to help in community movement. Initially, a user **501** and a merchant **505** may register with an issuer bank **503** and an acquirer bank **507**, respectively. During the registration process, the issuer bank **503** and the acquirer bank **505** may onboard the user **501** and the merchant **505**, respectively. Also, during the registration process, the user **501** may select an option for participating in the charity program by selecting an appropriate option in the onboarding form provided by issuer bank **503** to the user **501**. Upon successful registration, the user **501** may initiate a transaction with the merchant **505**. The user may perform the transaction using a POS device or by any non-POS methods such as online transactions. The merchant **505** may further send the details of the transaction to the payment network **509** (For example: Visa Network) through an acquirer bank **507**. Furthermore, the payment network **509** may send a request to the issuer bank **503** to retrieve the enrollment information with the authorization response. Upon the successful authorization, the issuer bank **503** may send the authorization response to the payment network **509** along with the information whether the user **501** is enrolled in the charity program. The payment network **509** may call an API to connect with the connecting device **103** if the user

**501** is enrolled in the charity program. Further, the connecting device **103** may send a request to philanthropic entity **105**, to retrieve the event data associated with the charity program for donation. The philanthropic entity **105** may be a charity organization or a non-profitable organization. Further, the connecting device **103** may receive the event data associated with the charity program which may include the details for providing charity. The event data associated with the charity program may include but not limited to, the quiz questions asked by the non-profitable organizations, where each correct answer may lead to charity or donations. Furthermore, the connecting device **103** may send the quiz data or the quiz questions to access point **511**. The access point **511** may be common services (For e.g., Visa Common services) which may be an intermediate between the payment network **509** and the user **501**. The access point **511** may send transaction receipt details along with the quiz data to the user **501**. The user **501** may provide the response or answers to the quiz data which is transmitted to the connecting device **103**. The connecting device **103** may finally send the response provided by the users **501** to the philanthropic entity **105**. The response provided by the user may trigger for contribution as the charity to the philanthropic entity **105**. However, if the user **501** is not enrolled in the charity program, then the payment network **509** sends the transaction receipt to the user **501** through the access point **511**.

**[0035]** Finally, the language used in the specification has been principally selected for readability and instructional purposes, and it may not have been selected to delineate or circumscribe the inventive subject matter. Accordingly, the disclosure of the embodiments of the disclosure is intended to be illustrative, but not limiting, of the scope of the disclosure.

**[0036]** With respect to the use of substantially any plural and/or singular terms herein, those having skill in the art can translate from the plural to the singular and/or from the singular to the plural as is appropriate to the context and/or application. The various singular/plural permutations may be expressly set forth herein for sake of clarity.

**[0037]** Although the invention has been described in detail for the purpose of illustration based on what is currently considered to be the most practical and preferred embodiments, it is to be understood that such detail is solely for that purpose and that the invention is not limited to the disclosed embodiments, but, on the contrary, is intended to cover modifications and equivalent arrangements that are within the spirit and scope of the appended claims. For example, it is to be

understood that the present invention contemplates that, to the extent possible, one or more features of any embodiment can be combined with one or more features of any other embodiment.

## **A METHOD AND CONNECTING DEVICE FOR ASSOCIATING USERS AND PHILANTHROPIC ENTITIES**

### **ABSTRACT**

The present disclosure relates to a method and a connecting device for associating users and philanthropic entities to help in community movement. In the present disclosure, initially a connecting device **103** may receive a request from an authorization entity to connect to a philanthropic entity **105**. The authorization entity may send the request to the connecting device **103** when the user device **101** initiates a transaction with a merchant. The authorization entity may determine if the user device **101** is enrolled in the charity program. Further, the connecting device **103** may send a request to retrieve the event data associated with the charity program to philanthropic entity **105**. The connecting device **103** may further transmit the retrieved event data associated with the charity program to the user device **101**. Finally, the connecting device **103** triggers the contribution as charity to the philanthropic entity **105** based on the received response.

1/5

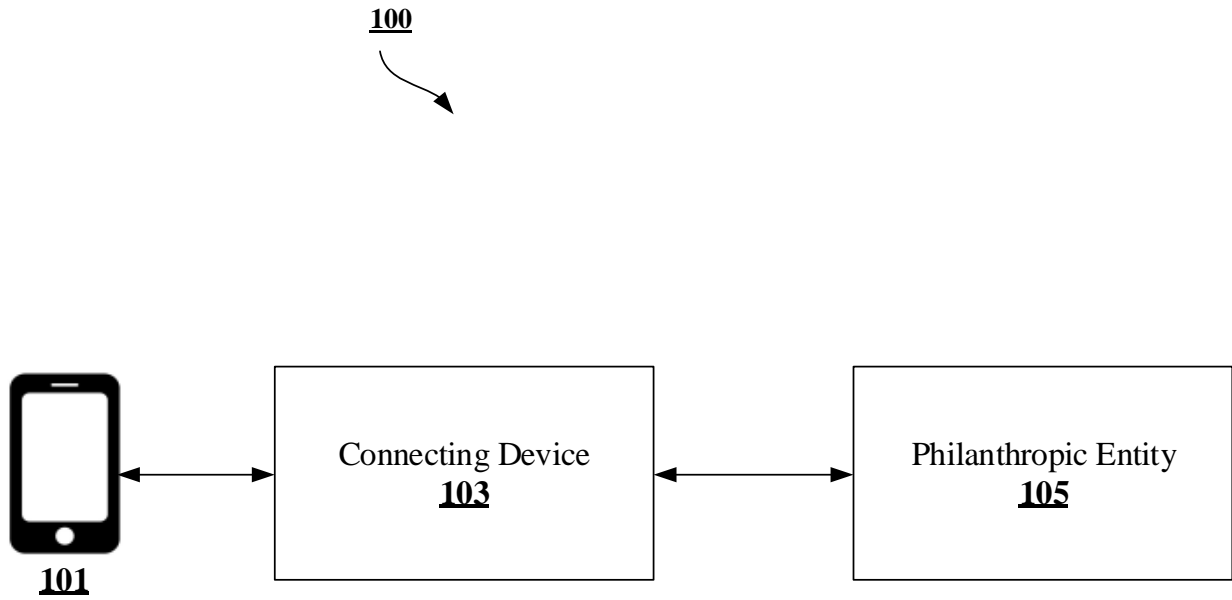

**FIG. 1**



2/5

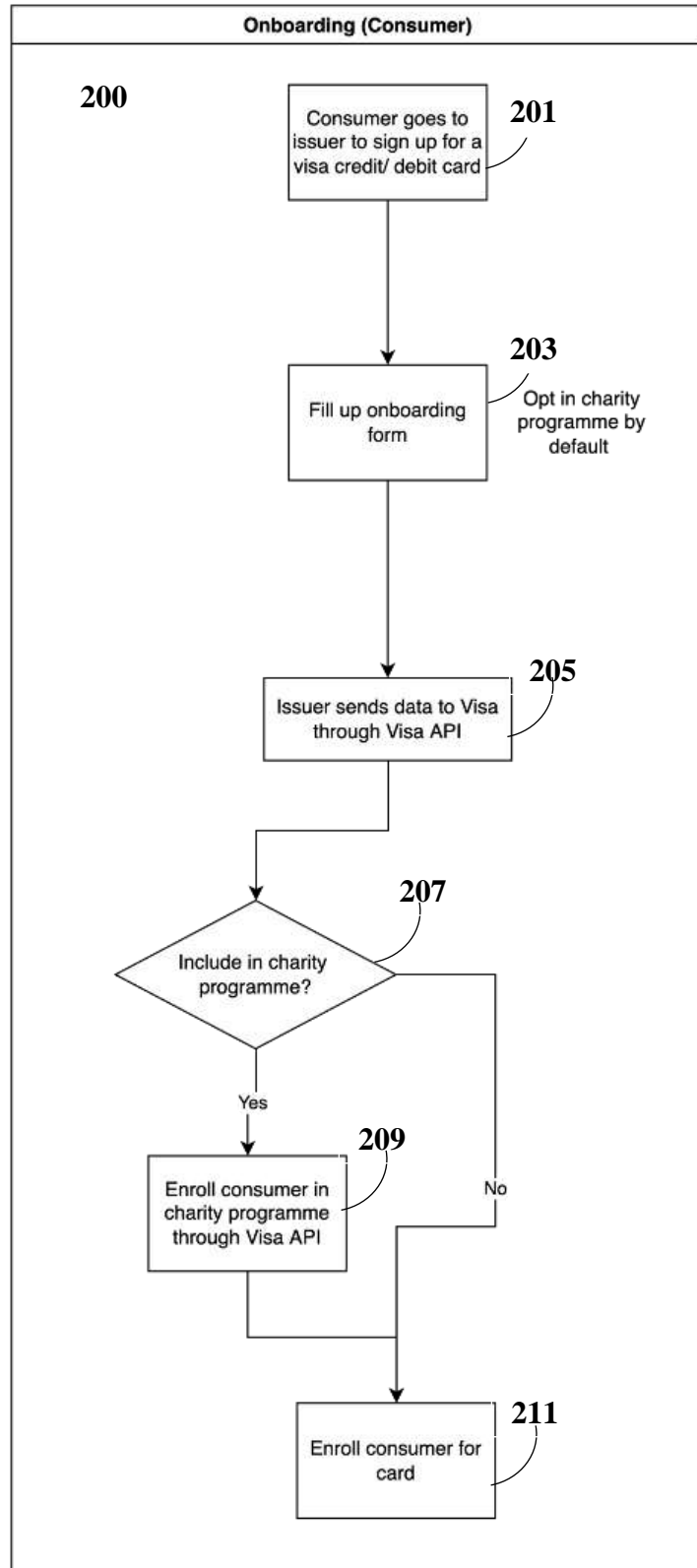
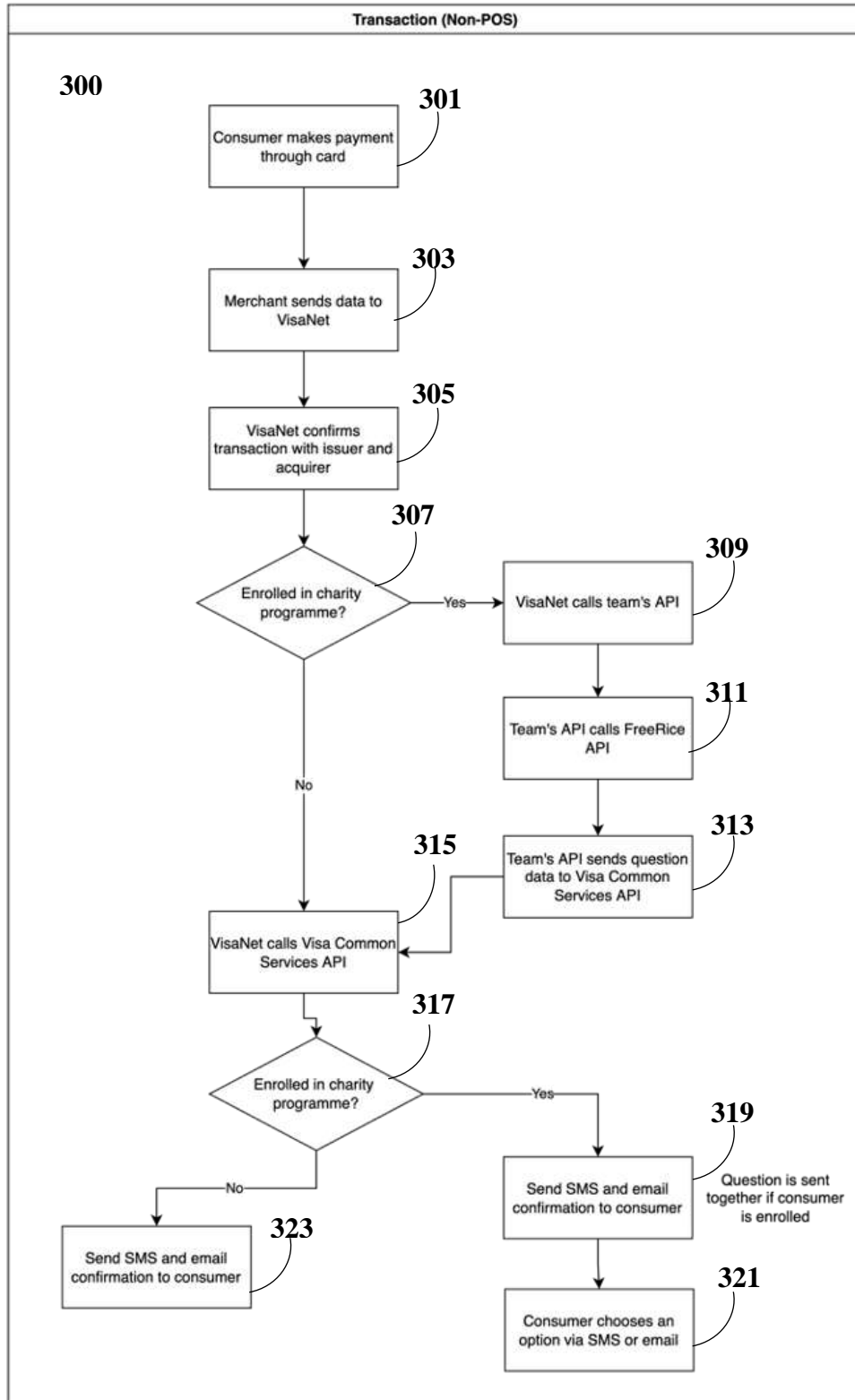

FIG. 2



**FIG. 3**

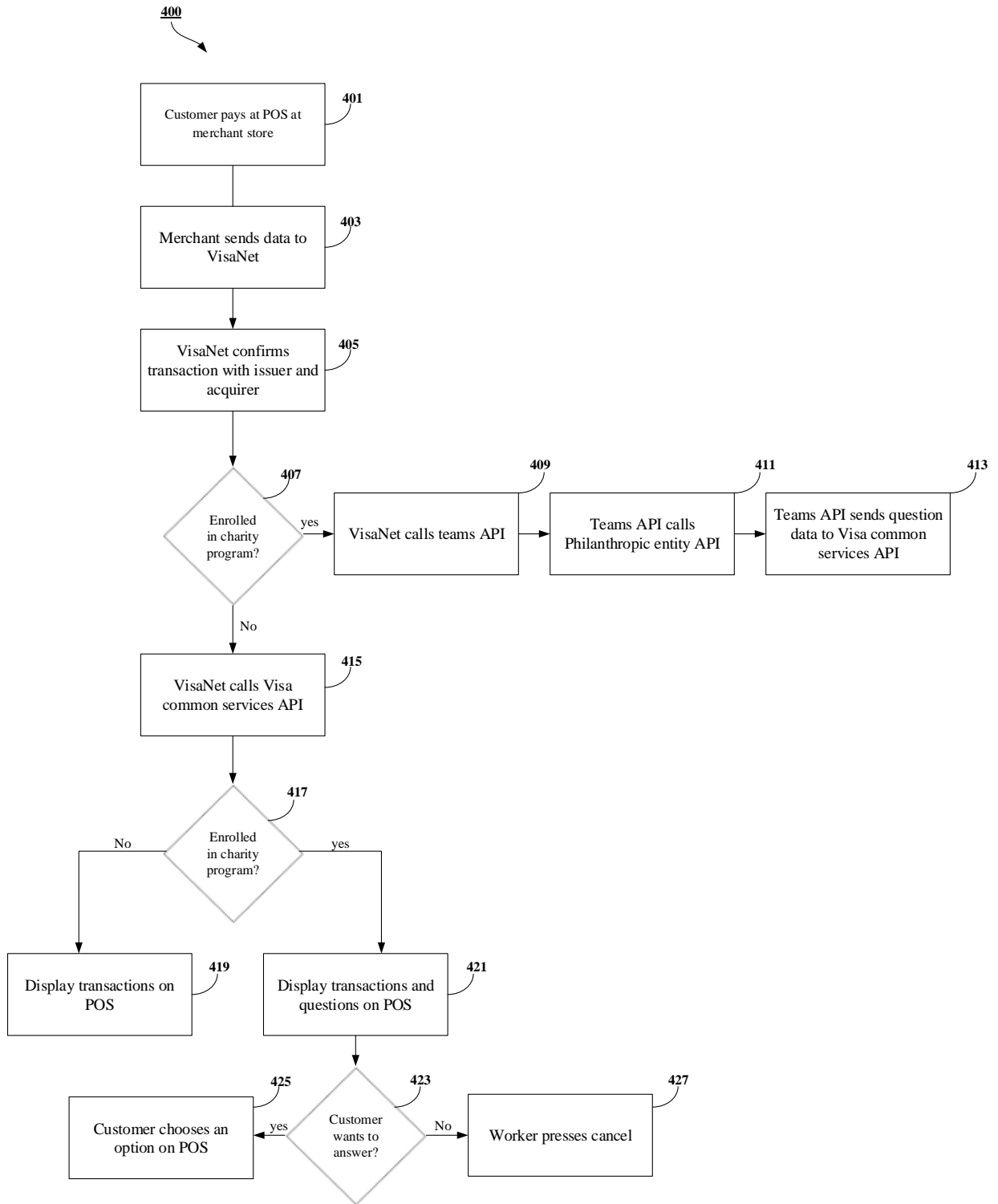

FIG. 4

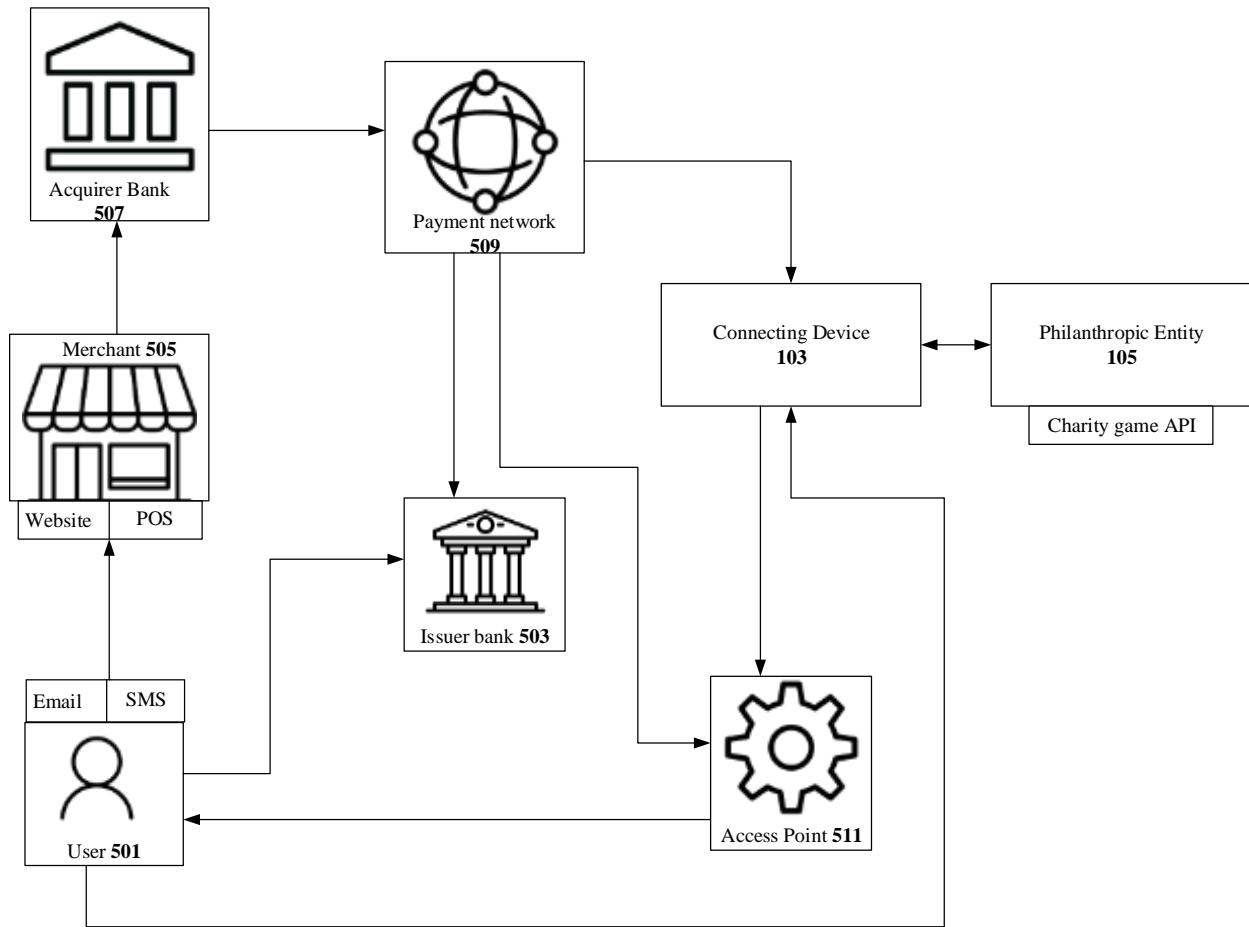

FIG. 5