

May 15, 2017

SECURITY SYSTEM WITH WIRELESS COMMUNICATION

InVue Security Products Inc.

Follow this and additional works at: <http://www.tdcommons.org/invue>

Recommended Citation

InVue Security Products Inc., "SECURITY SYSTEM WITH WIRELESS COMMUNICATION", Technical Disclosure Commons, (May 15, 2017)
<http://www.tdcommons.org/invue/13>



This work is licensed under a [Creative Commons Attribution 4.0 License](https://creativecommons.org/licenses/by/4.0/).

This Article is brought to you for free and open access by the Defensive Publications Series at Technical Disclosure Commons. It has been accepted for inclusion in InVue Defensive Publications by an authorized administrator of Technical Disclosure Commons.

SECURITY SYSTEM WITH WIRELESS COMMUNICATION

BACKGROUND OF THE INVENTION

[0002] Embodiments of the present invention relate generally to security systems for protecting items of merchandise, such as consumer electronics products.

[0003] It is common practice for retailers to provide demonstration models of relatively expensive consumer electronics products, such as handheld devices, tablets, and laptop computers, so that a potential purchaser may examine the product more closely and test the operation of its features. A working demonstration model, however, increases the possibility that the demonstration model will be stolen or removed from the display area by an unauthorized person. As a result, demonstration models of consumer electronics products are typically protected by a security system that permits a potential purchaser to examine and operate the product, while reducing the likelihood that the demonstration model will be stolen or removed from the display area.

[0004] The security system displays an item of merchandise so that a potential purchaser can readily view and, in some instances, operate the item when making a decision whether to purchase the item. At the same time, the item of merchandise is usually physically secured on the security system so as to prevent, or at least deter, theft of the item. The merchandise display security system may also include an alarm that is activated to alert store personnel in the event that a shoplifter attempts to separate the item of merchandise from the security system.

DETAILED DESCRIPTION OF EMBODIMENTS OF THE INVENTION

[0005] Referring to the accompanying figures wherein identical reference numerals denote the same elements throughout the various views, embodiments of security systems according to the present invention for protecting an item of merchandise against theft or unauthorized removal are disclosed. The item of merchandise may be any item, including any number of consumer electronics products (e.g. hand-held device, cellular phone, smart phone, tablet, laptop computer, etc.). The security systems described herein are operable for securing the item of merchandise against theft or authorized removal, while at the same time permitting a potential purchaser to

closely examine and operate the item of merchandise in a display area. The security system permits a potential purchaser to examine and test the item of merchandise, while reducing the likelihood that the item of merchandise will be stolen or removed from the display area by an unauthorized person. The systems shown and described herein are suitable for securing an item of merchandise in a residential or commercial environment, as well as a retail environment, and furthermore, is not intended to be limited to use only as a security display device for protecting against theft and/or unauthorized removal.

[0006] According to one embodiment shown in FIG. 1, the security system 10 generally comprises a sensor 12 configured to be secured to an item of merchandise 14. The sensor 12 may be electrically connected to an adapter cable 16 with a connector 17 that is configured to electrically connect to an input jack of the item of merchandise 14. The security system 10 may also include a base 18 that is configured to removably support the sensor 12 and the item of merchandise 14 thereon. In some embodiments, the base 18 and the sensor 12 include one or more contacts 28, 40 for facilitating contact charging when the sensor is supported on the base. In addition, the security system 10 also includes a cable 20 that is secured to the sensor 12 at one end and operably engaged with a recoiler 22 at an opposite end. As explained in further detail below, a sense circuit or loop defined through the cable 20 may be used to detect various security events associated with the cable, such as the cable being cut, shorted, and/or disconnected. The charging circuit allows for charging of the item of merchandise 14 and/or power source carried by the sensor 12. The sensor 12 may detect security events associated with the sensor and/or the item of merchandise 14, such as the item of merchandise being removed from the sensor.

[0007] The sensor 12 may be secured to the item of merchandise 14 using any desired technique, such as an adhesive and/or mechanical brackets. In addition, the adapter cable 16 may be hardwired to the sensor 12 at one end, and the connector 17 at the opposite end may be configured to be removably inserted into the input jack of the item of merchandise 14. Thus, the sensor 12 and the item of merchandise 14 may be electrically connected via the adapter cable 16 and connector 17. The sensor 12 may include a printed circuit board (PCB) 24, circuitry, or the like. Moreover, the sensor 12 may include a power source 26, such as a battery or capacitor. As noted above, the sensor 12 may include one or more electrical contacts 28. In some

embodiments, the sensor 12 includes a plurality of electrical contacts 28. The electrical contacts 28 may be in electrical communication with the PCB 24 and the adapter cable 16. Alternatively, the electrical contacts 28 may be electrically connected to only the adapter cable 16.

[0008] In some embodiments, the sensor 12 may not supply power to the item of merchandise 14 when the item is lifted from the base 18. Rather, the item of merchandise 14 may operate using its own power source when lifted from the base 18. Should a security event occur, the sensor 12 may utilize its power source 26 to generate a security signal as explained in further detail below.

[0009] The base 18 may be configured to be supported on a fixed support or display surface 48, such as a counter, shelf, fixture, or the like. Thus, the base 18 may be located entirely above the support surface 48. The base 18 may be secured to the support surface 48 using any desired technique such as an adhesive and/or fasteners. The base 18 may include a recoiler 22 as discussed above. As such, the cable 20 may be extended from the base 18 when the sensor 12 and the item of merchandise 14 are lifted from the base, and the cable may be retracted into the base when the sensor and the item of merchandise are returned to the base. The recoiler 22 may be spring biased in some embodiments such that the cable 20 is automatically retracted within the base 18. Furthermore, the base 18 may include a PCB 32, circuitry, or the like that is in electrical communication with the cable 20. In this regard, the cable 20 may include one or more electrical conductors extending along the length of the cable. In some cases, the cable 20 may include a pair of conductors for defining a sense loop or circuit and conducting an electrical signal. In other cases, the cable 20 may include a single conductor, such as an optical conductor for conducting an optical signal (e.g., a fiber optic cable).

[0010] As discussed above, the base 18 may include one or more electrical contacts 40. The contacts 28, 40 of the base 18 and the sensor 12 are configured to align with one another and contact one another when the sensor is supported on the base. Thus, the base 18 and the sensor 12 are in electrical communication with one another when the sensor is supported on the base. The base 18 may be electrically connected to a power source 42 which is configured to provide power to the base and the one or more electrical contacts 40 in the base. The power source 42 may include a connector at a free end (e.g., a USB or like plug). The base 18 may also include

charging circuitry 45 that is configured to facilitate power transfer from the external power source 42 and the electrical contacts 40. Thus, when the sensor 12 is supported on the base 18, power is able to be transferred between the contacts 28, 40 and to the sensor. The adapter cable 16 is electrically connected to the sensor contacts 28 as power is delivered such that power is provided to the item of merchandise 14. Therefore, the item of merchandise 14 may be powered by power transferred thereto and may be used to charge a battery associated with the item of merchandise. In some embodiments, any voltage adaption occurs in the base 18. Voltage adaption may be needed in order to accommodate different items of merchandise 14 that require different operating voltages. Any voltage adaption may occur prior to power being provided to the contacts 28 on the sensor 12. Thus, the sensor 12 and adapter cable 16 do not provide any voltage adaption. In one embodiment, the adapter cable connector 17 may include an LED or visual indicator that is activated when the item of merchandise 14 is being charged. The LED may be deactivated when the sensor 12 is lifted from the base 18.

[0011] An end of cable 20 may be mechanically and/or electrically secured to the sensor 12. In one example, the cable 20 may be attached to the sensor 12 with a swivel 44 or like connector (e.g., an audio jack connector) to allow for rotational movement between the sensor and the cable. The swivel 44 could be permanently attached to the sensor 12 or could be removably attached if desired. Although the aforementioned embodiments describe that power may be transferred via contact charging, it is understood that other techniques could be used to transfer power to sensor 12 and the item of merchandise 14. For example, inductive charging functionality could be employed for transferring power, or power may be provided via the cable 20.

[0012] Moreover, the sensor 12 may include wireless communication circuitry 30 (e.g., a RF transceiver) for communicating with a controller 60. The controller 60 may be any suitable device having wireless communication circuitry (e.g., a RF transceiver) configured to wirelessly communicate with various components of the security system 10, such as a wireless accumulator. The controller 60 may be configured to generate an alarm signal in response to a security event, which may be communicated wirelessly by the sensor 12 to the controller. For example, a security event may occur when the sensor 12 is removed from the item of

merchandise 14 in an unauthorized manner, or the adapter cable 16 is removed from the item of merchandise in an unauthorized manner. In some embodiments, the sensor 12 includes a switch 33 (e.g., a plunger switch) that is configured to detect when the sensor is removed from the item of merchandise 14 in an unauthorized manner.

[0013] The sensor 12, base 18, and/or controller 60 may further include an alarm mechanism, such as a piezoelectric transducer, for generating an audible alarm in response to a security event. For instance, FIG. 1 shows that the base 18 includes an alarm mechanism 34. The base 18 may also include a battery 31 or power source that is in electrical communication with the PCB 32. The base 18 may include a port or interface 36 that is configured to facilitate communication with a key 39. For example, the port 36 may facilitate wireless communication with a key 39 for arming or disarming the security system 10. In one embodiment, the key 39 is an infrared key configured to arm/disarm the alarm with a unique identifying code. In some embodiments, the key 39 is similar to the IR and IR2 keys manufactured by InVue Security Products Inc. The base 18 may include a switch 38 (e.g., a plunger switch) that is configured to detect when the base is removed from the support surface 48 in an unauthorized manner.

[0014] In another embodiment, FIGS. 2 and 3 show that the security system 10 may further include a remote disarming device 62. The remote disarming device 62 may be configured to communicate with a key 39 to arm and/or disarm an alarm, such as an alarm operably engaged with or housed within the controller 60. In some cases, the key 39 may be similar to that described above and configured to wirelessly communicate with the remote disarming device 62. The remote disarming device 62 may be operably coupled to the controller 60 using electrical conductors or via wireless communication. Moreover, in one example, the remote disarming device 62 may include an alarm mechanism for generating an alarm signal in response to a security event. The remote disarming device 62 may be located remotely from the sensor 12, base, 18, and controller 60 and may be configured to arm or disarm one or more alarms in communication with the remote disarming device.

[0015] In one embodiment, the security system 10 may be configured to be set up using only peel-and-stick adhesive. For example, sensor 12 may be mounted to the item of merchandise 14 with an adhesive, and the base 18 and controller 60 may be mounted to a support surface 48 with

an adhesive. In some cases, only a single cable may be utilized such as for the power source 42. Thus, the security system may be easily assembled and lacks clutter resulting from a number of cables being used in conventional security systems.

[0016] As discussed above, the sensor 12 may be configured to emit a wireless signal in response to a security event. In one embodiment, the base 18 and/or controller 60 may include wireless communication circuitry that is configured to communicate with the wireless communication circuitry 30 of the sensor 12. For example, the controller 60 may include wireless communication circuitry configured to receive the wireless signal emitted by the sensor 12 and to generate an alarm signal (e.g., an audible and/or a visible alarm) in response thereto. In some embodiments, the sensor 12 includes a radio transmitter that is configured to emit a signal at a frequency that is detectable by a radio receiver in the controller 60. Upon receipt of the signal, the controller 60 would generate an alarm signal. Other wireless communication techniques are possible such as, for example, radiofrequency (Zigbee or Sub-GHz band), Bluetooth, Bluetooth low energy (BLE), WiFi, or the like. The controller 60 may be configured to “listen” for the wireless signal emitted by the sensor 12 and generate an alarm signal upon receiving the signal. The controller 60 and sensor 12 may also be configured to communicate data to determine whether a security event has occurred. Thus, either one-way or two-way communication between the sensor 12 and the controller 60 may occur.

[0017] In another embodiment, the controller 60 may be configured to communicate with a plurality of sensors 12 and/or bases 18. For example, the controller 60 may be configured to wirelessly communicate with a plurality of sensors 12 (see FIG. 3). The controller 60 may be configured to communicate with any number of sensors 12 as well as detect when sensors are added to or removed from the security system 10. The controller 60 may be independent from the base 18 and remotely positioned with respect to the sensor 12 and the base 18. In some cases, the controller 60 may be positioned below a support surface 48, while the sensor 12 and base 18 are located above the support surface. The controller 60 may be configured to wirelessly communicate security signals and/or data with one or more sensors 12 or bases 18. For instance, as discussed above, the sensor 12 may be configured to emit a wireless signal in response to a security event that is detectable by the controller 60. In addition, the sensor 12 and controller 60

may be configured to exchange data. For example, the sensor 12 may be configured to obtain various data from the item of merchandise 14 and provide that data to the controller 60. The controller 60 may in turn store the data and/or transmit the data to one or more remote electronic devices 70.

[0018] The controller 60 may be paired with each of the sensors 12 and be configured to generate an alarm signal when communication with a sensor is lost. The controller 60 may also generate an alarm signal if the sensor 12 emits a security signal to indicate that an alarm event has occurred (e.g., the sensor is removed from the item of merchandise 14). The controller 60 may also be configured to communicate with a respective base 18 so that the base may generate an alarm signal when communication with an associated sensor 12 ceases or when the sensor emits a security signal. In other embodiments, the controller 60 may be integrated with the base 18.

[0019] It is understood that the cable 20 may be any suitable cord, tether, or the like. In addition, the cable 20 may include one or more electrical conductors for transmitting electrical, security, and/or communication signals. In addition, the cable 20 may be a single strand, multi-strand, or braided. The cable 20 may be flexible to facilitate extension and retraction with the base 18, and in some embodiments, may be formed of a cut-resistant material. Furthermore, the cable 20 may have various cross sections, such as round or flat. In some embodiments, the security system 10 may not include a recoiler 22. Thus, the cable 20 could be a straight or coiled cable that is secured to the sensor 12 at one end and electrically connected to base 18 at an opposite end.

[0020] Various sensing techniques may be employed for determining whether the cable 20 has been cut or removed from the sensor 12 in an unauthorized manner. For example, the cable 20 may include a pair of electrical conductors that define a sense loop therethrough. Thus, should the sense loop be interrupted (e.g., by cutting or shorting the cable 20), the PCB 24, 32 in the sensor 12 or the base 18, respectively may detect the interruption and initiate an alarm signal, such as by emitting a wireless signal that is detected by the controller 60.

[0021] A lock mechanism 50 may be disposed within the base 18 for locking the base to the sensor 12 to prevent the sensor and item of merchandise 14 from being lifted from the base. For

example, a fastener may be used to secure the base 18 to the sensor 12. Such a lock may be employed after hours in a retail environment to prevent unauthorized removal and further security of the item of merchandise 14, as the cable 20 will be inaccessible. It is also understood that the lock mechanism 50 could incorporate electro-mechanical means for locking the sensor 12 to the base 18. In one example, the lock mechanism 50 could be actuated in response to communication with a key 39. In some embodiments, the controller 60 may be configured to wirelessly communicate with the sensor 12 and/or base 18 to lock or unlock the lock mechanism 50.

[0022] The controller 60 may facilitate data communication with the system 10. For example, the controller 60 may be operably engaged with one or more remote electronic devices 70 configured to communicate data regarding an item of merchandise 14 for digital signage or various analytics. The remote electronic device 70 may be managed by a retailer. Likewise, the controller 60 may be configured to obtain data regarding the item of merchandise 14 and provide the data to the remote electronic device. For instance, the data may be the number of pickups of the sensor 12 off of the base 18, the number of put downs of the sensor onto the base, the power status of the item of merchandise 14, the manufacturer, serial, or model number of the item of merchandise, an identifier of the item of merchandise, the lock down status of the system 10, the alarm status of the system, the power level of a back-up battery in the sensor and/or base, etc. In addition, the controller 60 may be configured to receive data from a security system 10 that results in performance of a particular function, such as directing a camera to record the location of an alarming system 10 or actuating digital signage. In some cases, the item of merchandise 14 may be configured to communicate directly with the controller 60. For example, the item of merchandise 14 may include a software application that allows for communication with the controller 60.

[0023] In some embodiments, the controller 60 may be configured to communicate with one or more remote electronic devices 70 through a cloud network 80. In one particular embodiment, a plurality of controllers 60 and/or systems 10 are configured to communicate with one or more retailer's electronic devices 70 over the cloud network 80. For instance, the cloud network 80 may facilitate communication with a plurality of tablet devices used by sales

associates within a retail environment. Communication over the network 80 may occur wirelessly (e.g., via radiofrequency communication). One or more gateways and/or nodes may be used to facilitate communication between the controller 60 and the retailer's electronic device(s) 70. For instance, a gateway (e.g., a router) between the controller 60 and the cloud network may be configured to facilitate communication with a retailer's gateway and may be configured to allow the retailer to provide and receive data from the system 10. The retailer may be able to direct various commands via the cloud network 80 such as, for example, ensuring planogram compliance. In some embodiments, such commands could include powering up or down one or more items of merchandise 14, performing a roll call of one or more items of merchandise (either at a particular time or after an alarming event), determining a location of an alarming system 10, identifying a specific key that armed/disarmed/locked/unlocked a particular system 10, remotely enabling or disabling an item of merchandise, remotely locking down an item of merchandise, checking the power status of an item of merchandise, tracking usage of an item of merchandise, tracking one or more items of merchandise (e.g., via serial number), assigning particular keys 39 to authorized users, and/or directing a camera to record the location of an alarming system 10. As such, a retailer may be able to more effectively manage any number of features regarding one or more security systems 10.

[0024] In some embodiments the security system may communicate using a client-host network. In some cases, the controller 60 is configured to be the host device, while the sensors 12 may be the client devices. For example, an IP (internet protocol) bridge (e.g., IEEE 802.11 Wi Fi/803.3) can reside in the controller 60 or can be a single IP bridge that interfaces to individual controllers or sensors 12. The IP bridge may permit the client-host network to interface via the cloud based network 80 that allows retail store access to information collected by the security system.

[0025] As noted above, the item of merchandise 14 may include software or firmware for facilitating communication with the controller 60 and obtaining data. A retailer may install the software on an item of merchandise 14 for providing various information such as displaying interactive product content. The software may also allow for a retailer to remotely provide information to the item of merchandise 14, such as sending various updates, as well as interface

with the item of merchandise.

[0026] In one embodiment, the remote electronic device 70 may be configured to monitor security status of the security system 10. For example, the electronic device 70 may monitor whether all security devices 10 are powered and/or armed. The electronic device 70 may also be configured to monitor the “health” of the security system 10. For instance, the electronic device 70 may track removal of the sensor 12 off of the base 18, as well as determine when a component is coming to its end of life and needs replacement before a false alarm occurs. The electronic device 70 may also monitor battery aging and indicate when any battery in the security system 10 needs to be replaced before it expires. Moreover, the electronic device 70 may report on metrics and analytics, such as capturing and reporting customer activity with items of merchandise on display. For example, items of merchandise lifted from a base 18 and customer interaction with software applications installed on the items of merchandise can be captured. In addition, the electronic device 70 may be configured to automatically schedule a lock down of the sensor 12 to the base 18 (and release of lock down) based on store hours or programmed security profile.

[0027] In some embodiments and as discussed above, a wireless key 39 may be employed. In one example, the key 39 may be configured to temporarily silence an alarm for a predetermined period of time (e.g., 15-20 seconds). The alarm may be silenced while a sales associate is moving to the security device to deactivate or disarm the alarm. Silencing the alarm would not deactivate the alarm, as the sales associate will still need to present the key 39 to the base 18 or remote disarming device 62 to disarm the alarm. If the alarm is not disarmed within the predetermined period of time, the alarm will resume generation of an alarm signal. In some cases, the key 39 may only be configured to silence the alarm a single time until the alarm is disarmed within the predetermined time period. In any case, the sensor 12 and/or base 18 may be configured to generate a visual alarm (e.g., flashing LED) until the alarm is disarmed.

[0028] Furthermore, the key 39 may be configured to provide various data to a remote electronic device 70, such as via communication with the controller 60. The key 39 may be configured to communicate key usage key usage information to the controller 60 and/or electronic device 70. Providing such information may allow for real time tracking of which key

39 has interacted with a security system 10. Using such a system, auditing of the key 39 may provide a robust audit function that cannot be defeated by simply “losing” the key. In addition, the controller 60 and/or electronic device 70 may be configured to detect, based upon the transactions of the key 39, when a security system has been left unattended or is in a compromised state. For example, where the security system includes a lock, the controller 60 and/or electronic device 70 may be configured to alert a sales associate and/or store manager when the lock has been left unlocked (e.g., via a SMS message, email or computer generated call message).

[0029] The foregoing has described one or more embodiments of security systems for securing an item of merchandise from theft or unauthorized removal. Although various embodiments of the present invention have been shown and described, it will be apparent to those skilled in the art that various modifications thereto can be made without departing from the spirit and scope of the invention. Accordingly, the foregoing description is provided for the purpose of illustration only, and not for the purpose of limitation.

That which is claimed is:

1. A security system for securing an item of merchandise, comprising:
a sensor configured to be coupled to an item of merchandise;
a base configured to removably support the sensor and the item of merchandise thereon;
a controller configured to wirelessly communicate with the sensor; and
a disarming device remote from the sensor, the base, and the controller,
wherein the controller comprises an alarm configured to generate an alarm signal in response to a security event, and
wherein the disarming device is configured to arm or disarm the alarm.
2. The security system of Claim 1, further comprising a key configured to wirelessly communicate with the disarming device for arming or disarming the alarm.
3. The security system of Claim 1, wherein the controller is configured to communicate via a cloud-based network to one or more remote electronic devices.
4. The security system of Claim 1, wherein the sensor comprises wireless communication circuitry configured to emit a wireless signal in response to a security event.
5. The security system of Claim 4, wherein the controller comprises wireless communication circuitry configured to receive the emitted signal from the sensor and to generate an alarm signal in response thereto.
6. The security system of Claim 1, further comprising a cable connecting the sensor to the base, the cable comprising at least one conductor for defining a sense loop.
7. The security system of Claim 6, wherein the alarm is configured to generate an alarm signal when the item of merchandise is removed from the sensor or the sense loop is interrupted.
8. The security system of Claim 1, wherein the sensor is configured to emit a wireless signal that is detectable by the controller.
9. The security system of Claim 1, further comprising an adapter cable electrically

connecting the sensor to the item of merchandise, and wherein the sensor is configured to emit a wireless security signal in response to removal of the adapter cable from the item of merchandise that is detectable by the controller.

10. The security system of Claim 9, wherein the sensor is configured to obtain data from the item of merchandise and communicate the data to the controller.

11. The security system of Claim 1, further comprising a plurality of sensors and associated bases, wherein the controller is configured to wirelessly communicate with each of the sensors.

12. The security system of Claim 1, wherein the controller is independent of the base.

13. A security system for securing an item of merchandise, comprising:
a sensor configured to be coupled to an item of merchandise;
a base configured to removably support the sensor and the item of merchandise thereon;
a controller independent of the sensor and the base and configured to wirelessly communicate with the sensor; and
a disarming device,
wherein the controller comprises an alarm configured to generate an alarm signal in response to a security event, and
wherein the disarming device is configured to arm or disarm the alarm.

14. A method for securing an item of merchandise, comprising:
wirelessly communicating with a sensor coupled to an item of merchandise, the sensor and the item of merchandise being removably supported on a base;
generating an alarm signal with an alarm remote from the sensor and the base based on receiving a wireless signal from the sensor; and
disarming the alarm remotely from the sensor and the base.

15. The method of Claim 14, further comprising wirelessly communicating with a plurality of sensors.

16. The method of Claim 14, wherein wirelessly communicating comprises wirelessly

communicating security signal and data.

17. The method of Claim 14, wherein disarming comprises disarming the alarm remote from the sensor and the base.

ABSTRACT

Embodiments of the present invention are directed to security systems for securing an item of merchandise from theft or unauthorized removal. For example, the security system may include a sensor configured to be coupled to an item of merchandise and a base configured to removably support the sensor and the item of merchandise thereon. The security system may also include a controller independent of the sensor and the base and configured to wirelessly communicate with the sensor and a disarming device. The controller comprises an alarm configured to generate an alarm signal in response to a security event, and the disarming device is configured to arm or disarm the alarm.

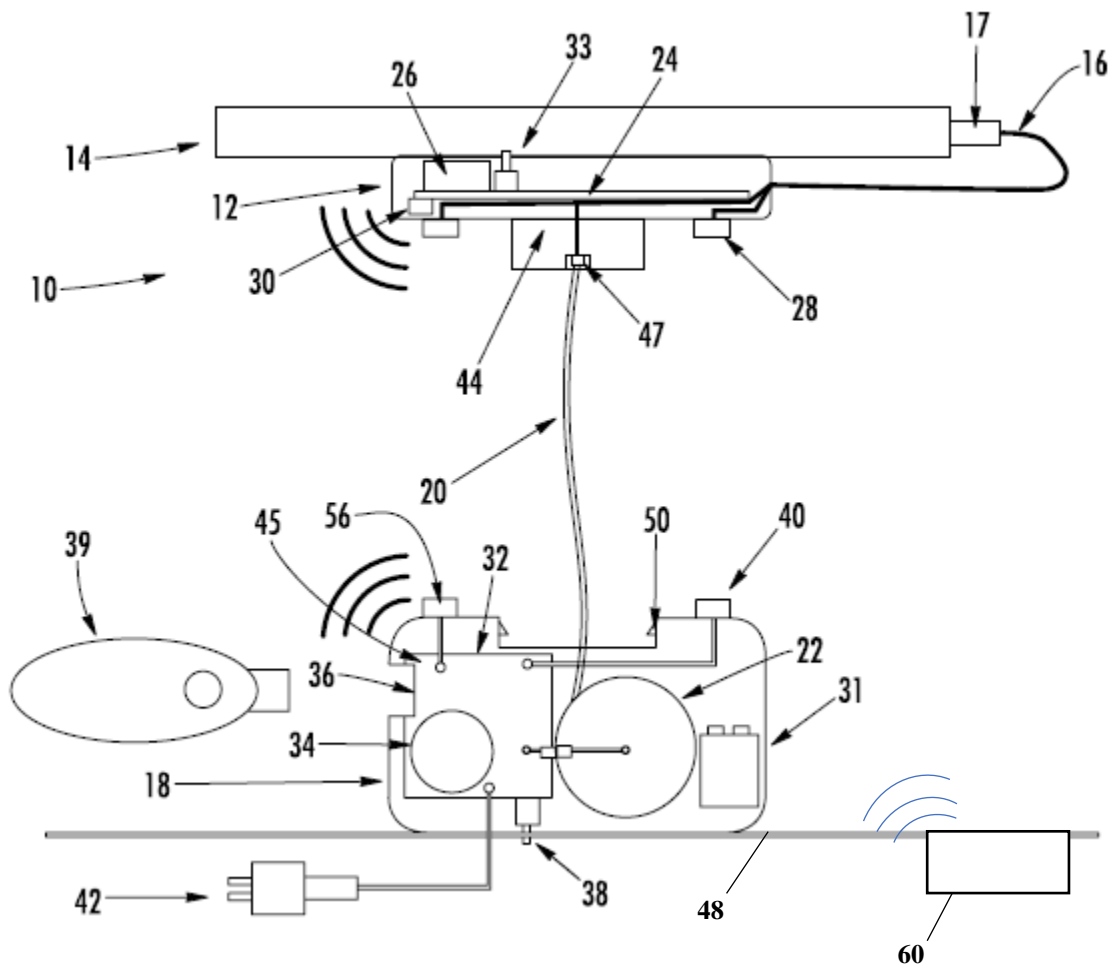

FIGURE 1

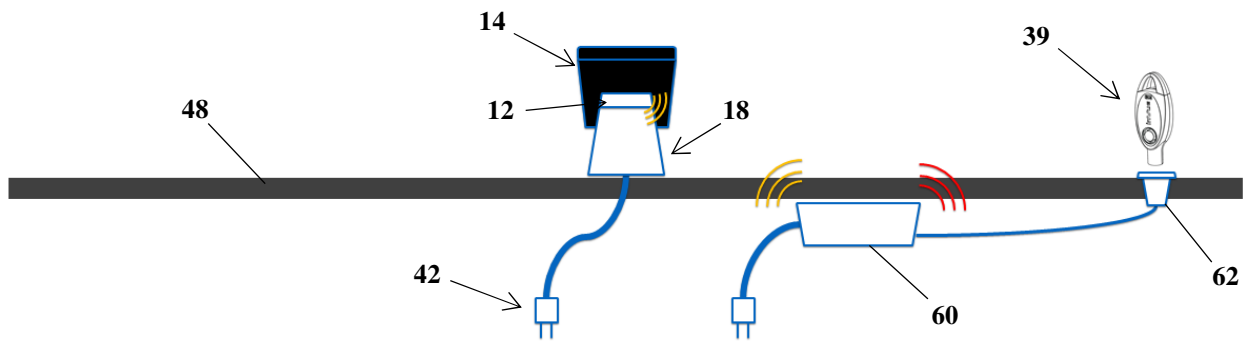
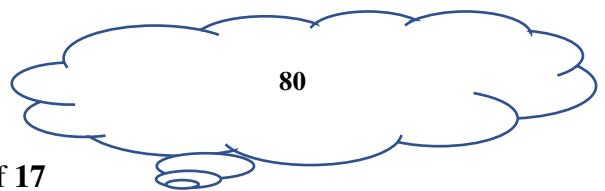

FIGURE 2



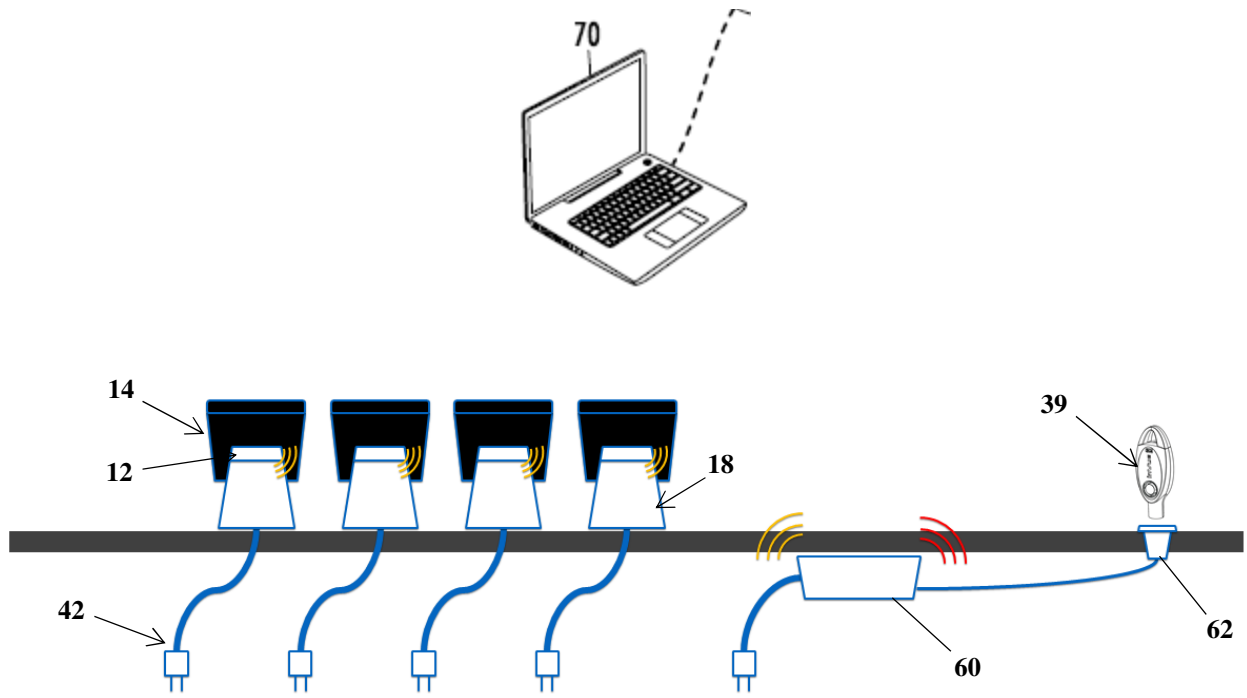

FIGURE 3